

LED Exterior Lamp

EL63015
INSTALLATION SHEET

START FROM HERE

- Prepare everything in a clear area.
- Read instructions carefully before you start assembly.
- Keep this instruction sheet for future reference.

Technical Support: 1-877-452-6858

Please Note:

- All Kuzco LED fixtures come with pre-wired LED module(s).
- Unless instructed to do so, please do not touch any part of the LED module(s) as any unnecessary contact with the module could cause permanent damage.

1. Use as directed:

This product serves exclusively lighting purposes and may:

- not be exposed to strong mechanical loads or to strong contamination.
- only be installed and operated after a condition inspection if the product is dirty or has been moistened through storage.

2. Technical Data:

- Power: 3 W
- Operating voltage: DC 3. 7V
- Luminous flux: 218LM
- LED: PHILIP 3014 / 23PCS
- Lithium Battery: 18650 / 2200mAH*2
- Charge: 5-7 H
- Work time: 7 H
- class: II
- Safety type: IP54

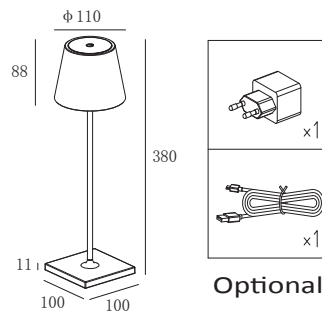

3. Charger:

- 1) Can use mobile phone charger to charge.
- 2) Optional: INPUT: AC100-240V 50/60Hz, OUTPUT: 5V --- 1A micro usb line: 1.2M.

4. Instructions:

- 1) Quick touch: touch one time, light is on; touch again, light is off.
- 2) Long touch: Touch a long time, the light lumen increases gradually; Move away from the head, the light keeps the same, Light will be 100% on and will not change if touching time is over 4s. Touch again, the light lumen decrease gradually until light off.
- 3) When charging, the indicator on the top will be red, once finish charging, become green.

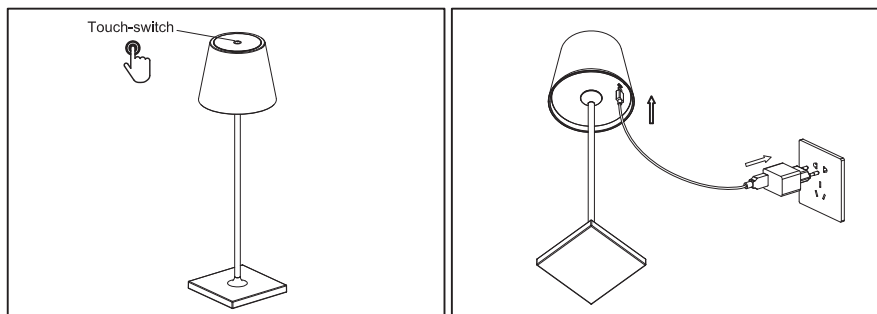

5. Attention:

- 1) Before the first using, please charge firstly, please remove the silicone protective cover, then insert the charging line to charge.
- 2) During the using, the tilt angle of the pole can not be more than 15° , otherwise will fall down.
- 3) Battery have the function of overcharge protection.
- 4) Please refer to the local environmental law to recycle and dispose the battery.

KUZCO

19054 28th Avenue Surrey, BC Canada V3S 6M3
T: 604 538 7162 TF: 1-855 85 KUZCO F: 604 538 7196
W: kuzcolighting.com
20160527